

Name of Innovative Active Learning Technique

PBL

Course Name and Code : Design Engineering (ME348)

Class and Div. : TY B. Tech.

Department : Mechanical Engineering

Prepared by,
Dr. R. G. Desavale
Asso. Professor
Department of Mechanical Engineering,
R. I. T., Rajaramnagar

Purpose and Motivation

- to give students the opportunity to develop knowledge and skills through engaging projects set around challenges and problems they may face in the real world.
- students gain mastery through the application of their knowledge rather than rote memorization.
- to engage and give them ownership over their own learning.

Suitability of Technique to course

an opportunity for students to critique and revise their approach when they encounter obstacles. As they continue to actively explore a real-world problem, they acquire a deeper knowledge that requires further analysis — they have to keep going.

Procedure of Technique

- Defining the Problem. PBL projects should start with students asking questions about a problem. ...
- Generating Ideas. Next, students should be given the opportunity to brainstorm and discuss their ideas for solving the problem. ...
- Prototyping Solutions. ...
- Testing and evaluation.

Outcomes of Technique

- The finding suggests that by engaging in PBL, students can develop certain skills that cannot be acquired in a conventional teaching environment.
- PBL enables self-learning and prepares students to deal with different situations and challenges on the ground while inculcating professionalism to act in real-life situations.

Photographs and Student Response

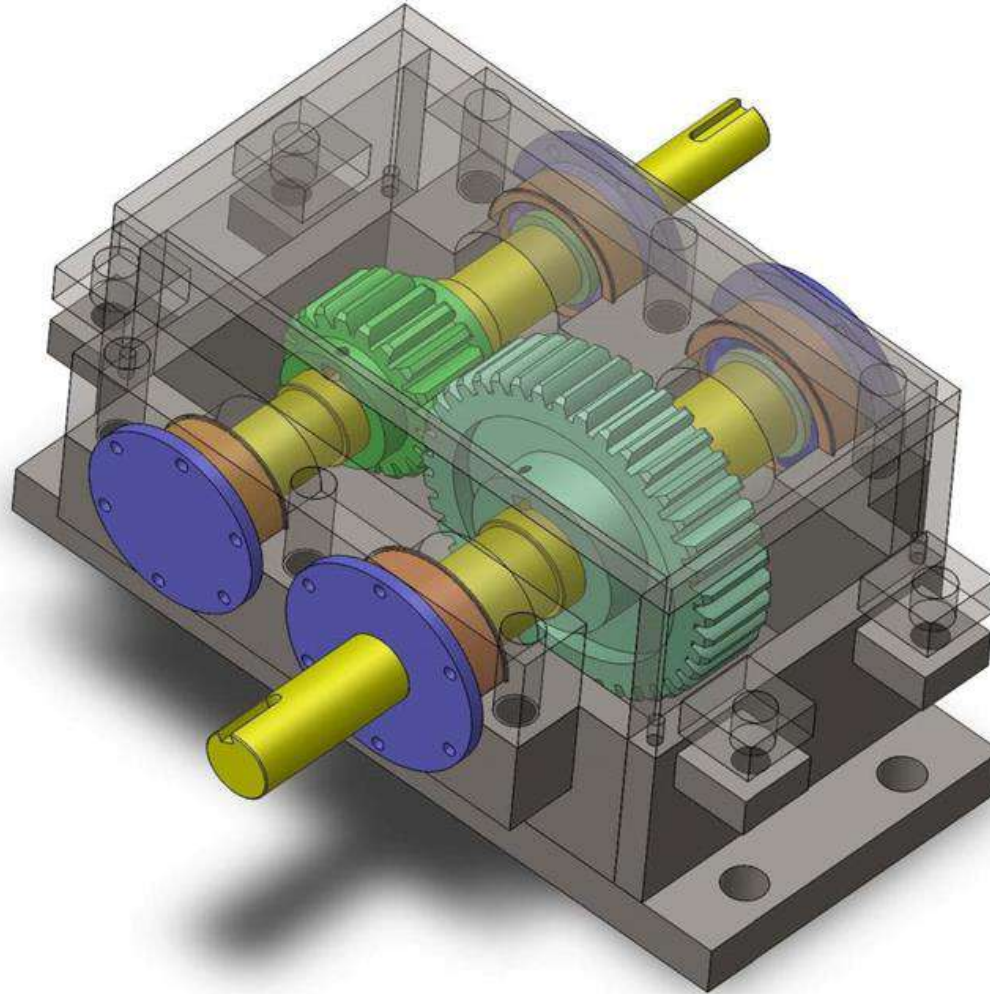

THANK YOU!!!!